

HIGH TEMPERATURE LOW POWER OSCILLATOR FOR AUTOMOTIVE AEC-Q100 SERIES „HTLPO-AUT“ 115.2 -137.0 MHz

FEATURES

- + AEC-Q100 with extended temperature range
- + 100% pin-to-pin drop-in replacement to quartz and MEMS based XO
- + Highest Temperature Low Power Oscillator for Low Cost
- + Excellent long time reliability-outperforms quartz-based XO
- + Supply voltage of 1.8V or 2.25V to 3.63V
- + Low power consumption of 3.8 mA typical at 1.8V
- + Excellent total frequency stability as low as ± 20 ppm
- + Outstanding G-sensitivity of 0.1 PPB/G
- + LVCMOS/LVTTL compatible output
- + Pb-free, RoHS and REACH compliant

APPLICATIONS

- + Automotive, extreme temperature and other high-rel electronics
- + Infotainment systems, collision detection devices, and in-vehicle networking
- + Power train control
- + etc.

GENERAL DATA^[1]

PARAMETER AND CONDITIONS	SYMBOL	MIN.	TYP.	MAX.	UNIT	CONDITION
FREQUENCY RANGE						
Output Frequency Range	f	115.2	-	137	MHz	
FREQUENCY STABILITY AND AGING						
Frequency Stability	F_stab	-20	-	+20	PPM	Inclusive of initial tolerance at 25°C, 1st year aging at 25°C, and variations over operating temperature, rated power supply voltage and load (15 pF \pm 10%).
		-25	-	+25	PPM	
		-30	-	+30	PPM	
		-50	-	+50	PPM	
OPERATING TEMPERATURE RANGE						
Operating Temperature Range	T_use	-40	-	+85	°C	Industrial, AEC-Q100 Grade 3
		-40	-	+105	°C	Extended Industrial, AEC-Q100 Grade 2
		-40	-	+125	°C	Automotive, AEC-Q100 Grade 1
		-55	-	+125	°C	Extended Temperature, AEC-Q100
SUPPLY VOLTAGE AND CURRENT CONSUMPTION						
Supply Voltage	V _{DD}	1.62	1.8	1.98	V	All voltages between 2.25V and 3.63V including 2.5V, 2.8V, 3.0V and 3.3V are supported. Contact PETERMANN-TECHNIK for 1.5V support.
		2.25	-	3.63	V	
Current Consumption	I _{DD}	-	6.0	8	mA	No load condition, f = 125 MHz, V _{DD} = 2.25V to 3.63V
		-	4.9	6	mA	No load condition, f = 125 MHz, V _{DD} = 1.62V to 1.98V
LVCMOS OUTPUT CHARACTERISTICS						
Duty Cycle	DC	45	-	55	%	All V _{DDs}
Rise/Fall Time	Tr, Tf	-	1.5	3.0	ns	V _{DD} = 2.25V - 3.63V, 20% - 80%
		-	1.5	2.5	ns	V _{DD} = 1.8V, 20% - 80%
Output High Voltage	VOH	90%	-	-	V _{DD}	IOH = -4 mA (V _{DD} = 3.0V or 3.3V) IOH = -3 mA (V _{DD} = 2.8V and V _{DD} = 2.5V) IOH = -2 mA (V _{DD} = 1.8V)
Output Low Voltage	VOL	-	-	10%	V _{DD}	IOL = 4 mA (V _{DD} = 3.0V or 3.3V) IOL = 3 mA (V _{DD} = 2.8V and V _{DD} = 2.5V) IOL = 2 mA (V _{DD} = 1.8V)

GENERAL DATA^[1] (continued)

PARAMETER AND CONDITIONS	SYMBOL	MIN.	TYP.	MAX.	UNIT	CONDITION
INPUT CHARACTERISTICS						
Input High Voltage	V _{IH}	70%	-	-	V _{DD}	Pin 1, OE
Input Low Voltage	V _{IL}	-	-	30%	V _{DD}	Pin 1, OE
Input Pull-up Impedence	Z _{in}	-	100	-	kΩ	Pin 1, OE logic high or logic low
STARTUP AND RESUME TIMING						
Startup Time	T _{start}	-	-	5	ms	Measured from the time V _{DD} reaches its rated minimum value
Enable/Disable Time	T _{oe}	-	-	130	ns	f = 115.2 MHz. For other frequencies, T _{oe} = 100 ns + 3* cycles
JITTER						
RMS Period Jitter	T _{jitt}	-	1.6	2.5	ps	f = 125MHz, 2.25V - 3.63V
		-	1.8	3	ps	f = 125MHz, V _{DD} = 1.8V
Peak-to-peak Period Jitter	T _{pk}	-	12	20	ps	f = 125 MHz, V _{dd} = 2.5V, 2.8V, 3.0V or 3.3V
		-	14	30	ps	f = 125 MHz, V _{dd} = 1.8V
RMS Phase Jitter (random)	T _{phj}	-	0.7	-	ps	f = 125 MHz, Integration bandwidth = 900 kHz to 7.5 MHz
		-	1.5	-	ps	f = 125 MHz, Integration bandwidth = 12 kHz to 20 MHz
ENVIRONMENTAL COMPLIANCE						
Moisture sensitivity level					MSL1@ 260°C	
G-Sensitivity					0.1PPB/G	
MAXIMUM OPERATING JUNCTION TEMPERATURE^[2]						
Max Operating Temperature (ambient)			Maximum Operating Junction Temperature			
85°C			95°C			
105°C			115°C			
125°C			135°C			

PIN DESCRIPTION

PIN	SYMBOL		FUNCTIONALITY
1	OE/NC	Output Enable	H ^[2] : specified frequency output L: output is high impedance. Only output driver is disabled.
		No connect	Any voltage between 0 and V _{DD} or Open ^[2] . Specified frequency output. Pin 1 has no function.
2	GND	Power	Electrical ground ^[3]
3	OUT	Output	Oscillator output
4	V _{DD}	Power	Power supply voltage ^[3]

TOP VIEW

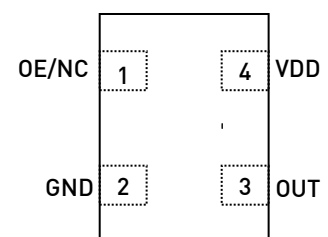

Note: 1. All Min and Max limits are specified over temperature and rated operating voltage with 15 pF output load unless otherwise stated. Typical values are at 25°C and nominal supply voltage.
2. Datasheet specifications are not guaranteed if junction temperature exceeds the maximum operating junction temperature.
3. In OE mode, a pull-up resistor of 10kΩ or less is recommended if pin 1 is not externally driven. If pin 1 needs to be left floating, use the NC option.
4. A capacitor value of 0.1 μF or higher between V_{DD} and GND is required.

TEST CIRCUIT AND WAVEFORM [4]

FIGURE 1. TEST CIRCUIT

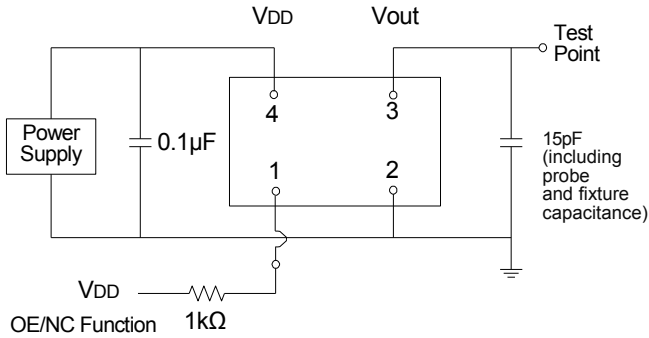

Note: 5. Duty Cycle is computed as $Duty\ Cycle = TH/Period$

FIGURE 2. WAVEFORM

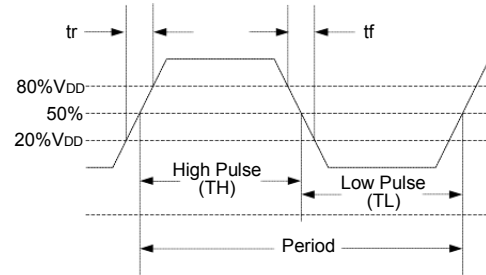

TIMING DIAGRAMS

FIGURE 3. STARTUP TIMING (OE MODE)

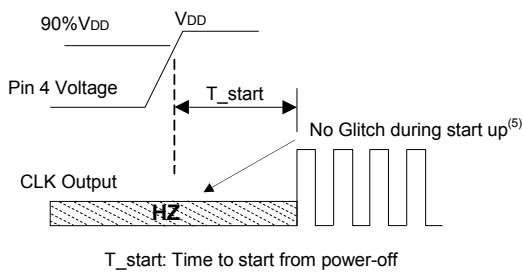

FIGURE 4. OE ENABLE TIMING (OE MODE ONLY)

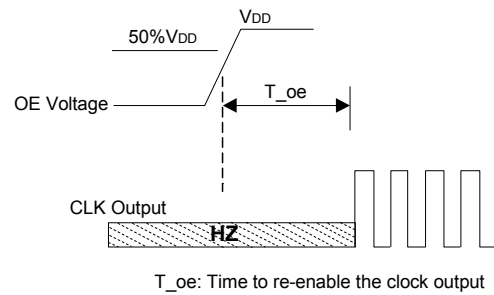
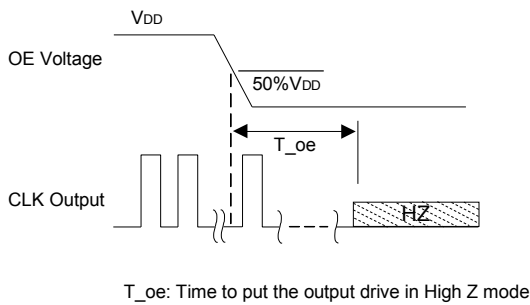

FIGURE 5. OE DISABLE TIMING (OE MODE ONLY)



Note: 6. HTLPO-AUT has "no runt" pulses and "no glitch" output during startup or resume.

PROGRAMMABLE DRIVE STRENGTH

The HTLPO-AUT includes a programmable drive strength named SoftLevel feature to provide a simple, flexible tool to optimize the clock rise/fall time for specific applications. Benefits from the programmable drive strength feature are:

- + Improves system radiated electromagnetic interference (EMI) by slowing down the clock rise/fall time
- + Improves the downstream clock receiver's (RX) jitter by decreasing (speeding up) the clock rise/fall time.
- + Ability to drive large capacitive loads while maintaining full swing with sharp edge rates.

For more detailed information about rise/fall time control and drive strength selection, please contact the application engineers of Petermann-Technik.

EMI REDUCTION BY SLOWING RISE/FALL TIME (SoftLevel FUNCTION)

Figure 6 shows the harmonic power reduction as the rise/fall times are increased (slowed down). The rise/fall times are expressed as a ratio of the clock period. For the ratio of 0.05, the signal is very close to a square wave. For the ratio of 0.45, the rise/fall times are very close to near-triangular waveform. These results, for example, show that the 11th clock harmonic can be reduced by 35 dB if the rise/fall edge is increased from 5% of the period to 45% of the period.

FIGURE 6. HARMONIC EMI REDUCTION AS A FUNCTION OF SLOWER RISE/FALL TIME (SoftLevel FUNCTION)

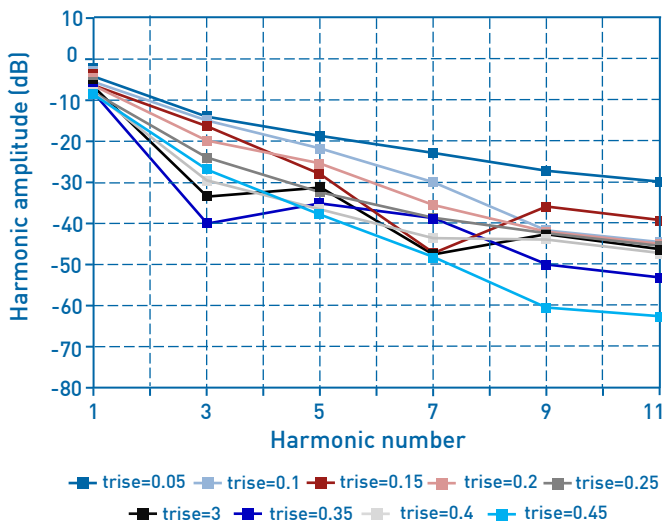

JITTER REDUCTION WITH FASTER RISE/FALL TIME

Power supply noise can be a source of jitter for the downstream chip-set. One way to reduce this jitter is to increase rise/fall time (edge rate) of the input clock. Some chipsets would require faster rise/fall time in order to reduce their sensitivity to this type of jitter. Refer to the Rise/Fall Time Tables to determine the proper drive strength.

HIGH OUTPUT LOAD CAPABILITY

The rise/fall time of the input clock varies as a function of the actual capacitive load the clock drives. At any given drive strength, the rise/fall time becomes slower as the output load increases. As an example, for a 3.3V HTLPO-AUT device with default drive strength setting, the typical rise/fall time is 0.46 ns for 5 pF output load. The typical rise/fall time slows down to 1 ns when the output load increases to 15 pF. One can choose to speed up the rise/fall time to 0.72 ns by then increasing the drive strength setting on the HTLPO-AUT.

The HTLPO-AUT can support up to 30 pF in maximum capacitive loads with up to 3 additional drive strength settings. Refer to the Rise/Fall Time Tables (Table 1 to 5) to determine the proper drive strength for the desired combination of output load vs. rise/fall time.

HTLPO-AUT DRIVE STRENGTH SELECTION

Tables 1 through 5 define the rise/fall time for a given capacitive load and supply voltage.

1. Select the table that matches the HTLPO-AUT nominal supply voltage (1.8V, 2.5V, 2.8V, 3.0V, 3.3V).
2. Select the capacitive load column that matches the application requirement (5 pF to 30 pF)
3. Under the capacitive load column, select the desired rise/fall times.
4. The left-most column represents the part number code for the corresponding drive strength.
5. Add the drive strength code to the part number for ordering purposes.

CALCULATING MAXIMUM FREQUENCY

Based on the rise and fall time data given in Tables 1 through 5, the maximum frequency the oscillator can operate with guaranteed full swing of the output voltage over temperature as follows:

$$\text{Max. frequency} = \frac{1}{5 \times \text{Tr}_f_{20/80}}$$

where $\text{Tr}_f_{20/80}$ is the typical value for 20%-80% rise/fall time.

EXAMPLE 1

Calculate f_{MAX} for the following condition:

- + $V_{\text{DD}} = 3.3\text{V}$ (Table 5)
- + Capacitive Load: 30pF
- + Desired Tr/f time = 1.46 ns (rise/fall time part number code=U)

Part number for the above example:

HTLPO-AUT33-2520-E-25-WT-125.000MHz-T-S

Drive strength code is inserted here. Standard setting is "S"

RISE/FALL TIME (20% TO 80%) vs C_{LOAD}

TABLE 1. VDD = 1.8V RISE/FALL TIMES FOR SPECIFIC C_{LOAD}

RISE/FALL TIME TYP (NS)		
Drive Strength \ C _{LOAD}	5 pF	15 pF
T	0.93	n/a ⁽⁶⁾
E	0.78	n/a
U	0.70	1.48
S for standard	0.65	1.30

TABLE 2. VDD = 2.5V RISE/FALL TIMES FOR SPECIFIC C_{LOAD}

RISE/FALL TIME TYP (NS)		
Drive Strength \ C _{LOAD}	5 pF	15 pF
R	1.45	n/a
B	1.09	n/a
T	0.62	1.28
E	0.54	1.00
S for standard	0.43	0.96
F	0.34	0.88

TABLE 3. VDD = 2.8V RISE/FALL TIMES FOR SPECIFIC C_{LOAD}

RISE/FALL TIME TYP (NS)			
Drive Strength \ C _{LOAD}	5 pF	15 pF	30 pF
R	1.29	n/a	n/a
B	0.97	n/a	n/a
T	0.55	1.12	n/a
E	0.44	1.00	n/a
S for standard	0.34	0.88	n/a
F	0.29	0.81	1.48

TABLE 4. VDD = 3.0V RISE/FALL TIMES FOR SPECIFIC C_{LOAD}

RISE/FALL TIME TYP (NS)			
Drive Strength \ C _{LOAD}	5 pF	15 pF	30 pF
R	1.22	n/a	n/a
B	0.89	n/a	n/a
S for standard	0.51	1.00	n/a
E	0.38	0.92	n/a
U	0.30	0.83	n/a
F	0.27	0.76	1.39

TABLE 5. VDD = 3.3V RISE/FALL TIMES FOR SPECIFIC C_{LOAD}

RISE/FALL TIME TYP (NS)			
Drive Strength \ C _{LOAD}	5 pF	15 pF	30 pF
R	1.16	n/a	n/a
B	0.81	n/a	n/a
S for standard	0.46	1.00	n/a
E	0.33	0.87	n/a
U	0.28	0.79	1.46
F	0.25	0.72	1.31

Note: 7. "n/a" in Table 1 to Table 5 indicates that the resulting rise/fall time from the respective combination of the drive strength and output load does not provide rail-to-rail swing and is not available.

PIN 1 CONFIGURATION OPTIONS (OE or NC)

Pin 1 of the HTLPO-AUT can be factory-programmed to support two modes: Output enable (OE) or No Connect (NC).

OUTPUT ENABLE (OE) MODE

In the OE mode, applying logic Low to the OE pin only disables the output driver and puts it in Hi-Z mode. The core of the device continues to operate normally. Power consumption is reduced due to the inactivity of the output. When the OE pin is pulled High, the output is typically enabled in <math><1\mu\text{s}</math>.

NO CONNECT (NC) MODE

In the NC mode, the device always operates in its normal mode and output the specified frequency regardless of the logic level on pin 1. Table 6 below summarizes the key relevant parameters in the operation of the device in OE or NC mode.

TABLE 6. OE vs. NC

	OE	NC
Active current 20 MHz (max, 1.8V)	6 mA	6 mA
OE disable current (max. 1.8V)	4 mA	N/A
OE enable time at 110 MHz (max)	130 ns	N/A
Output driver in OE disable	High Z	N/A

OUTPUT ON STARTUP AND RESUME

The HTLPO-AUT comes with gated output. Its clock output is accurate to the rated frequency stability within the first pulse from initial device startup or when the output driver is enabled.

In addition, the HTLPO-AUT supports “no runt” pulses and “no glitch” output during startup or when the device output driver is enabled as shown in the waveform captures in Figure 7 and Figure 8.

FIGURE 7. STARTUP WAVEFORM vs. V_{DD}

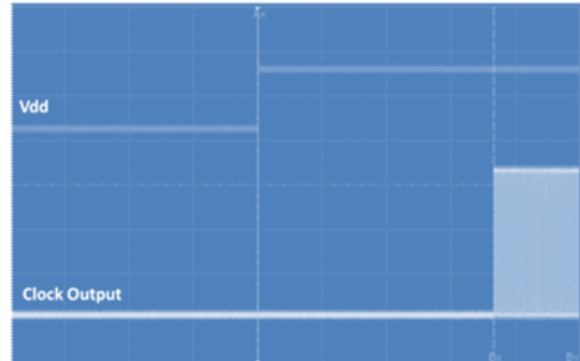
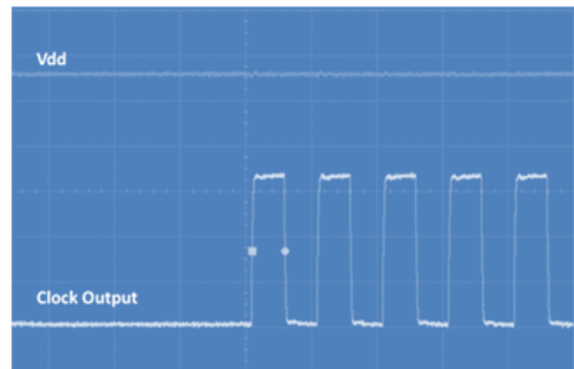

FIGURE 8. STARTUP WAVEFORM vs. V_{DD} (ZOOMED-IN VIEW OF FIGURE 7)



DIMENSIONS AND PATTERNS

PACKAGE SIZE - DIMENSIONS (UNIT:MM)

2.0 X 1.6 X 0.75 MM

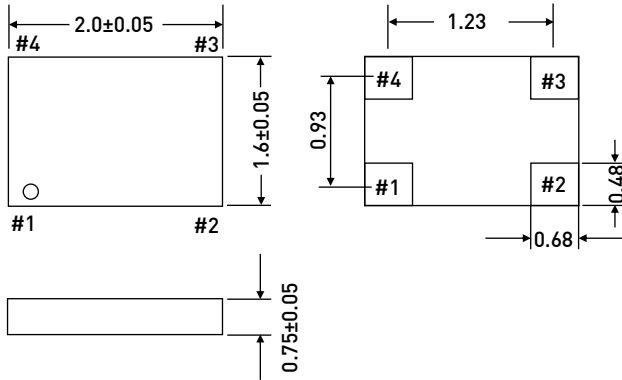

RECOMMENDED LAND PATTERN (UNIT:MM) ^[6]

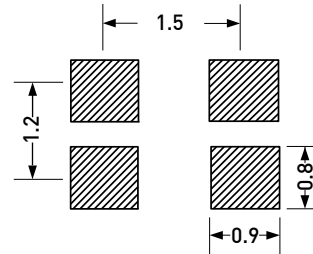

PACKAGE SIZE - DIMENSIONS (UNIT:MM)

2.5 X 2.0 X 0.75 MM

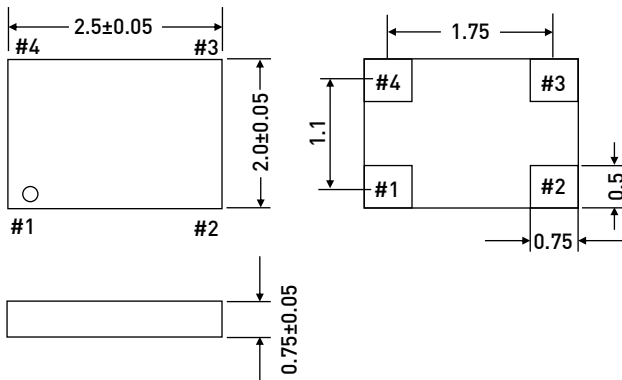

RECOMMENDED LAND PATTERN (UNIT:MM)

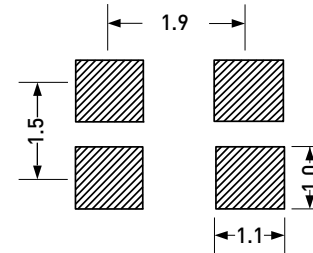

PACKAGE SIZE - DIMENSIONS (UNIT:MM)

3.2 X 2.5 X 0.75 MM

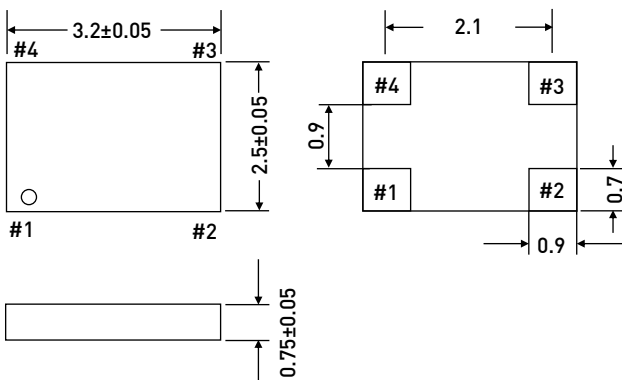

RECOMMENDED LAND PATTERN (UNIT:MM)

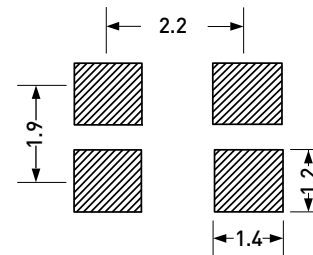

DIMENSIONS AND PATTERNS

PACKAGE SIZE - DIMENSIONS (UNIT:MM)

5.0 X 3.2 X 0.75 MM

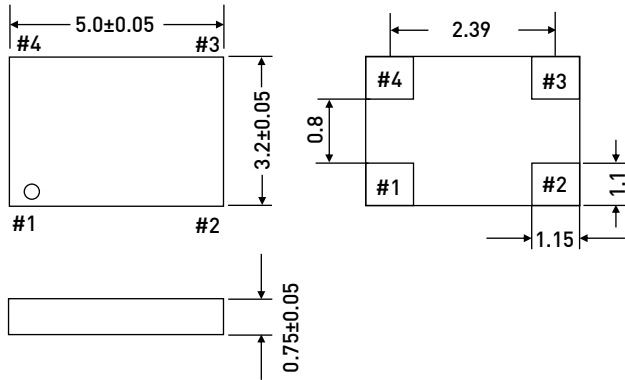

RECOMMENDED LAND PATTERN (UNIT:MM) [7]

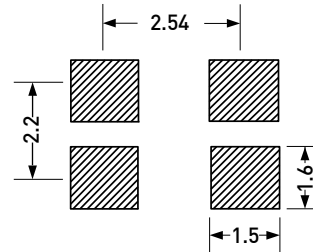

PACKAGE SIZE - DIMENSIONS (UNIT:MM)

7.0 X 5.0 X 0.90 MM

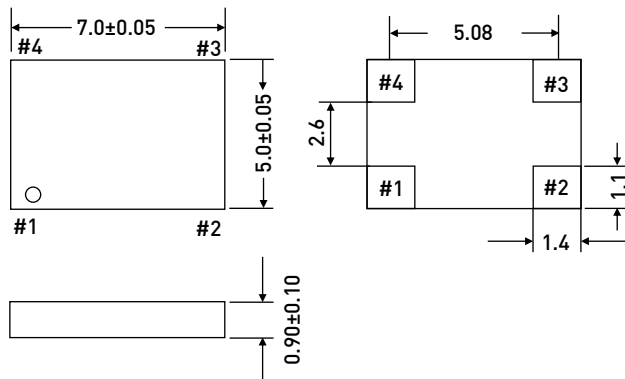

RECOMMENDED LAND PATTERN (UNIT:MM)

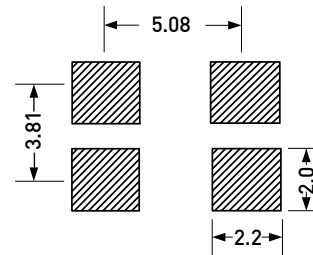

REFLOW SOLDER PROFILE

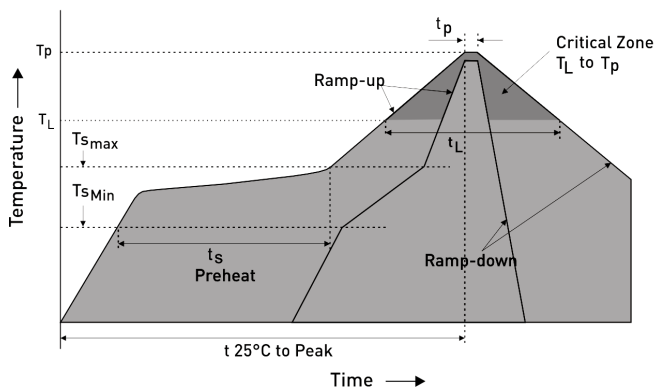

IPC/JEDEC Standard	IPC/JEDEC J-STD-020
Moisture Sensitivity Level	Level 1
TS MAX to TL (Ramp-up Rate)	3°C/second Maximum
Preheat	
- Temperature Minimum (TS MIN)	150°C
- Temperature Typical (TS TYP)	175°C
- Temperature Typical (TS MAX)	200°C
- Time (tS)	60 - 180 Seconds
Ramp-up Rate (TL to TP)	3°C/second Maximum
Time Maintained Above:	
- Temperature (TL)	217°C
- Time (TL)	60 - 150 Seconds
Peak Temperature (TP)	260°C Maximum
Target Peak Temperature (TP Target)	255°C
Time within 5°C of actual peak (tP)	20 - 40 Seconds
Max. Number of Reflow Cycles	3
Ramp-down Rate	6°C/second Maximum
Time 25°C to Peak Temperature (t)	8 minutes Maximum

ORDERING INFORMATION

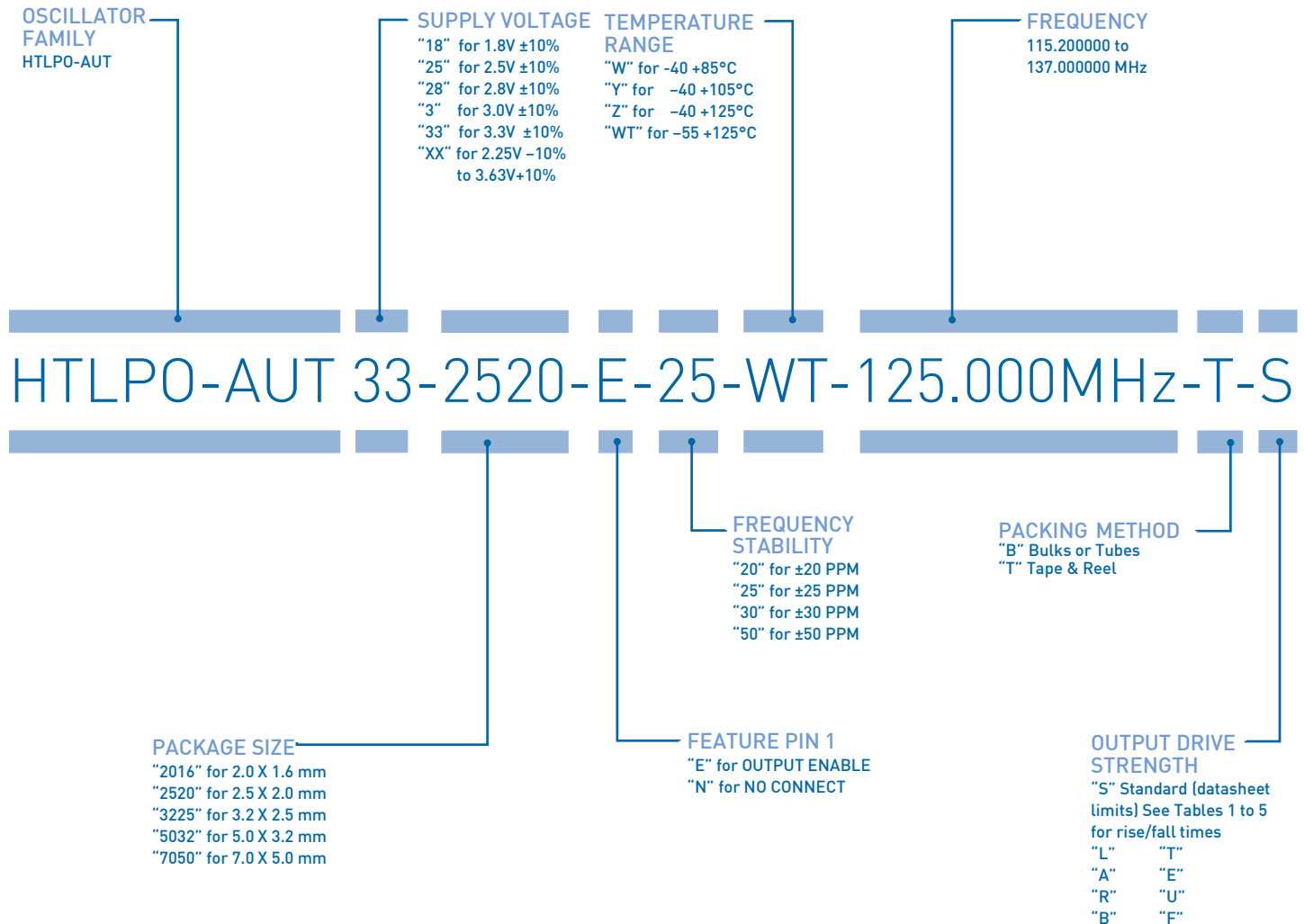

EXAMPLE: HTLPO-AUT33-2520-E-25-WT-125.000MH-T-S

[PLEASE CLICK HERE TO CREATE YOUR OWN ORDERING CODE](#)

FOR THE TEMPERATURE: -40 +85°/ -55 +125°C PLEASE SEE LPO-AUT & HTLPO-AUT PRODUCT SPECIFICATIONS



PREMIUM QUALITY BY PETERMANN-TECHNIK



OUR COMPANY IS CERTIFIED ACCORDING TO ISO 9001:2015 IN OCTOBER 2016 BY THE DMSZ CERTIFIKATION GMBH.

THIS IS FOR YOU TO ENSURE THAT THE PRINCIPLES OF QUALITY MANAGEMENT ARE FULLY IMPLEMENTED IN OUR QUALITY MANAGEMENT SYSTEM AND QUALITY CONTROL METHODS ALSO DOMINATE OUR QUALITY STANDARDS.