

LOW POWER TCXO & VCTCXO OSCILLATOR

SERIES „TCVCTO-1“ 1.0—80.0 MHz

FEATURES

- + 100% pin-to-pin drop-in replacement to quartz and MEMS based VCTCXO
- + Ultra Performance Oscillator for Low Cost
- + TCXO function active when Pin 1 = not connected
- + Wide tuning range up to ± 50 ppm
- + Excellent long time reliability—outperforms quartz-based XO
- + Frequency stability as low as ± 1.5 ppm (± 0.5 and ± 1 ppm optionally)
- + Outstanding long term aging
- + LVCMOS compatible output with option for EMI reduction
- + Packages available 2.5x2.0; 3.2x2.5; 5.0x3.2; 7.0x5.0 mm
- + Pb-free, RoHS and REACH compliant / MSL1@260°C

APPLICATIONS

- + WiFi, 3G, LTE, SDI, Ethernet, SONET, DSL
- + Telecom, networking, smart meter, wireless, test instrumentation
- + etc.

GENERAL DATA

PARAMETER AND CONDITIONS	SYMBOL	MIN.	TYP.	MAX.	UNIT	CONDITION
Output Frequency Range	f	1	–	80	MHz	
Initial Tolerance	F_init	-1	–	1	PPM	At 25°C
Stability Over Temperature	F_stab	-1.5	–	+1.5	PPM	Over operating temperature range at rated nominal power supply voltage and load (see ordering codes on page 7) ± 1.5 ppm is available in -20 to 70 °C temp. range only. Contact PETERMANN-TECHNIK for ± 0.5 ppm and ± 1 ppm options.
		-2	–	+2	PPM	
		-2.5	–	+2.5	PPM	
		-5	–	+5	PPM	
Supply Voltage	F_VDD	–	50	–	PPB	$\pm 10\%$ VDD ($\pm 5\%$ for VDD = 1.8V)
Output Load	F_load	–	0.1	–	PPM	15 pF $\pm 10\%$ of load
First year Aging	F_aging	-1.5	–	+1.5	PPM	25°C
10-year Aging		-3.5	–	+3.5	PPM	25°C
Stability vs. Temperature Slope	F_slope	–	0.1	–	PPM/°C	
Operating Temperature Range	T_use	-20	–	+70	°C	Extended Commercial
		-40	–	+85	°C	Industrial
Storage Temperature Range	T_stor	-65	–	+150		
Supply Voltage	VDD	1.71	1.8	1.89	V	Contact PETERMANN-TECHNIK for any other supply voltage option.
		2.25	2.5	2.75	V	
		2.52	2.8	3.08	V	
		2.70	3.0	3.3	V	
		2.97	3.3	3.63	V	
Pull Range	PR	$\pm 12.5, \pm 25, \pm 50$			PPM	
Upper Control Voltage	VC_U	VDD-0.1	–	–	V	All VDDs. Voltage at which maximum deviation is guaranteed.
Control Voltage Range	VC_L	–	–	0.1	V	
Control Voltage Input Impedance	Z_vc	100	–	–	k Ω	
Frequency Change Polarity	–	positive slope			–	
Control Voltage -3dB Bandwidth	V_BW	–	–	8	kHz	
Current Consumption	IDD	–	31	33	mA	No load condition, f = 20 MHz, VDD = 2.5V, 2.8V or 3.3V.
		–	29	31	mA	No load condition, f = 20 MHz, VDD = 1.8V.
OE Disable Current	I_OD	–	–	31	mA	VDD = 2.5V, 2.8V or 3.3V, OE = GND, output is pulled down
		–	–	30	mA	VDD = 1.8 V. OE = GND, output is pulled down
Standby Current	I_std	–	–	70	μ A	VDD = 2.5V, 2.8V or 3.3V, ST = GND, output is pulled down.
		–	–	10	μ A	VDD = 1.8V. ST = GND, output is pulled down.

Note:

- All electrical specifications in the above table are specified with 15 pF output load at default drive strength and for all VDD(s) unless otherwise stated.

GENERAL DATA (continued)

PARAMETER AND CONDITIONS	SYMBOL	MIN.	TYP.	MAX.	UNIT	CONDITION
Duty Cycle	DC	45	-	55	%	All VDDs
LVCMOS Rise/Fall Time	Tr, Tf	-	1.5	2	ns	LVCMOS option. Default rise/fall time, All VDDs, 10% - 90% VDD.
EMI reduction Rise/Fall Time	EMI reduction Rise/Fall Time Table				ns	EMI reduction option. Frequency and supply voltage dependent.
Output Voltage High	VOH	90%	-	-	VDD	OH = -7 mA, IOL = 7 mA, (VDD = 3.3V, 3.0V) IOH = -4 mA, IOL = 4 mA, (VDD = 2.8V, 2.5V) IOH = -2 mA, IOL = 2 mA, (VDD = 1.8V)
Output Voltage Low	VOL	-	-	10%	VDD	
Input Voltage High	VIH	70%	-	-	VDD	Pin 1, OE or ST
Input Voltage Low	VIL	-	-	30%	VDD	Pin 1, OE or ST
Input Pull-up Impedance	Z_in	-	100	250	kΩ	
Startup Time	T_start	-	-	10	ms	Measured from the time VDD reaches its rated minimum value
OE Enable/Disable Time	T_oe	-	-	150	ns	f = 80 MHz. For other frequencies, T_oe = 100 ns + 3 cycles
Resume Time	T_resume	-	6	10	ms	Measured from the time ST pin crosses 50% threshold
RMS Period Jitter	T_jitt	-	1.7	2	ps	f = 10 MHz, VDD = 2.5V, 2.8V or 3.3V
		-	1.7	2	ps	f = 10 MHz, VDD = 1.8V
RMS Phase Jitter (random)	T_phj	-	0.5	1	ps	f = 10 MHz, Integration bandwidth = 12 kHz to 20 MHz, All VDDs

Note:

- All electrical specifications in the above table are specified with 15 pF output load and for all VDD(s) unless otherwise stated.

PIN DESCRIPTION

PIN	SYMBOL	FUNCTIONALITY
		V control Voltage control
		Output Enable H or Open[2]: specified frequency output L: output is high impedance. Only output driver is disabled.
1	VC/OE/ST/NC	Standby H or Open[2]: specified frequency output L: output is low (weak pull down). Device goes to sleep mode. Supply current reduces to I_std.
		NC No connect (input receiver off)
2	GND	Power Electrical and case ground
3	CLK	Output Oscillator output
4	VDD	Input Power Power supply voltage

TOP VIEW

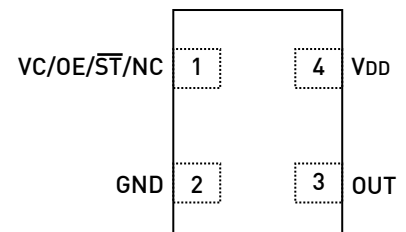

Note:

- A pull-up resistor of <10 kΩ between OE/ ST pin and VDD is recommended in high noise environment when the device operates in OE/ST mode.

TIMING DIAGRAMS

ST/OE MODE

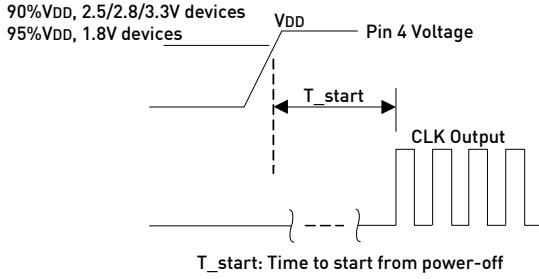

ST MODE ONLY

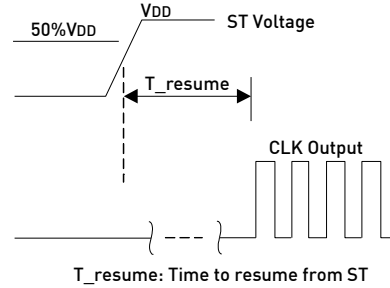

PHASE NOISE PLOT

PHASE NOISE, 10MHZ CARRIER, 3.3V, LVCMOS OUTPUT, TCXO

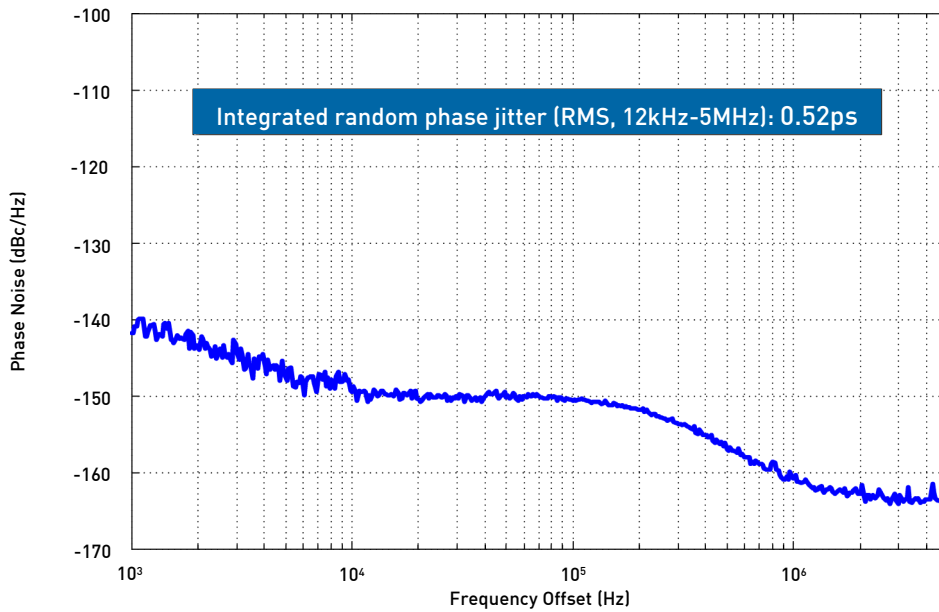

EMI REDUCTION OPTION

The adjustable output is available as a standard option for the TCX0-1 (TCX0 & VCTCX0). The adjustable EMI reduction option is used typically for EMI reduction similar to that of a clipped sinewave output common to many quartz based TCXOs.

In the EMI reduction mode, the slower rise/fall edges of the output waveform reduce the higher clock harmonics in a digital clock signal, minimizing EMI radiation at these harmonics. The table below shows the actual rise/fall time in relation to the desired output frequency and the supply voltage with a 10 kΩ / 10pF load. Rail-to-rail swing of the output is maintained for these supported frequencies.

PARAMETER	SYMBOL	MIN.	TYP.	MAX.	UNIT	CONDITION
Rise/Fall Time	Tr, Tf	4.0	6.5	9.5	ns	1-26MHz, 1.8V, 3.0 and 3.3V, MHz 10k and 10 pF, 20%-80% VDD
		2.5	4.0	6.0	ns	1-26MHz, 2.5V and 2.8V, MHz 10k and 10 pF, 20%-80% VDD
		1.5	3.5	5.0	ns	26-40MHz, 1.8V, 3.0V and 3.3V, MHz 10k and 10 pF, 20%-80% VDD
		1.5	2.5	4.5	ns	26-40 MHz, 2.5V and 2.8V, MHz 10k and 10 pF, 20%-80% VDD

EMI REDUCTION WAVEFORM EXAMPLES AND CORRESPONDING HARMONICS REDUCTION

Figures below illustrate the harmonic power reduction as the rise/fall times are slowed from the standard squarewave output to that of the EMI reduction output. In general, the 1.8V device shows the lowest harmonics and provides best EMI performance comparing to devices with higher operating voltages.

LVC MOS and EMI reduction Outputs, VDD = 3.3V

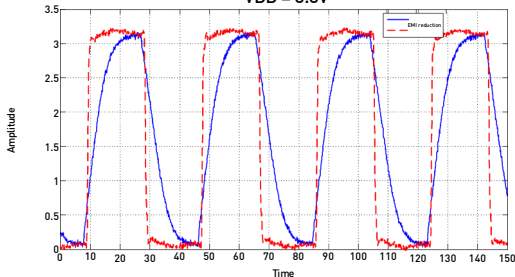

Odd Harmonic Power Comparison for LVC MOS and EMI reduction Outputs, VDD = 3.3V

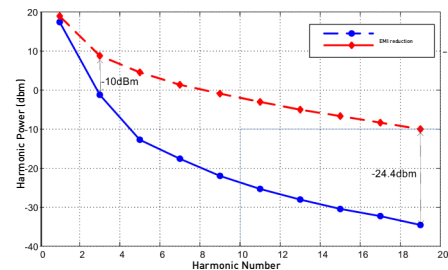

LVC MOS and EMI reduction Outputs, VDD = 2.5V

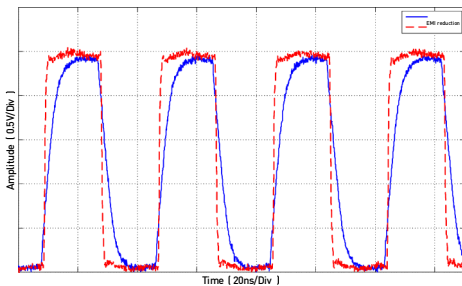

Odd Harmonic Power Comparison for LVC MOS and EMI reduction Outputs, VDD = 2.5V

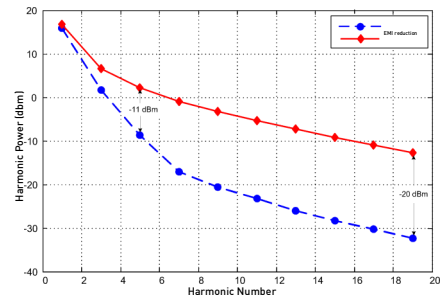

LVC MOS and EMI reduction Outputs, VDD = 1.8V

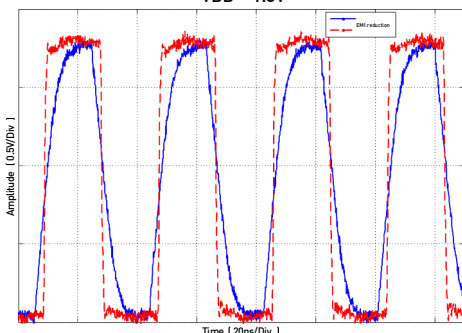

Odd Harmonic Power Comparison for LVC MOS and EMI reduction Outputs, VDD = 1.8V

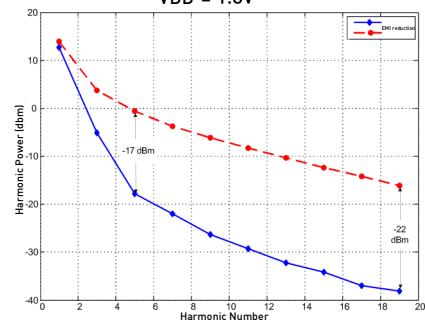

DIMENSIONS AND PATTERNS

PACKAGE SIZE – DIMENSIONS (UNIT:MM)

2.7X 2.4 X 0.75 MM (100% compatible with 2.5 x 2.0 mm footprint)

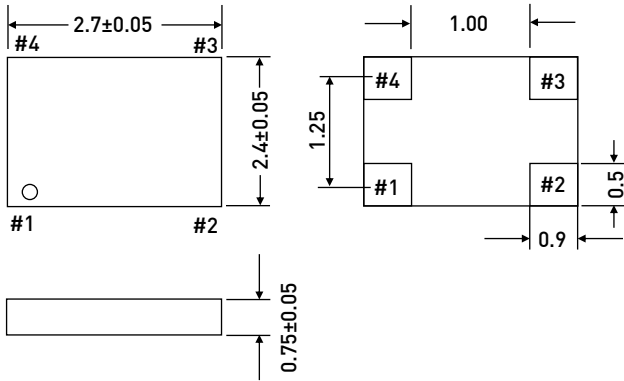

RECOMMENDED LAND PATTERN (UNIT:MM) ^[3]

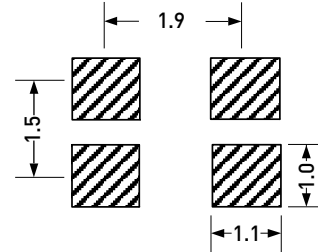

PACKAGE SIZE – DIMENSIONS (UNIT:MM)

3.2 X 2.5 X 0.75 MM

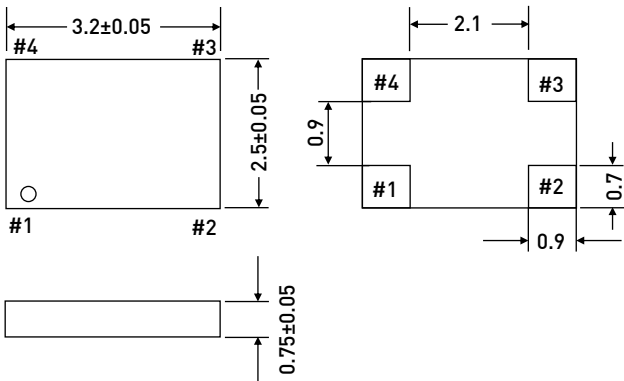

RECOMMENDED LAND PATTERN (UNIT:MM) ^[3]

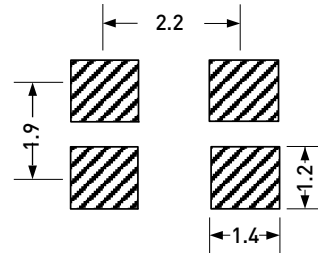

PACKAGE SIZE – DIMENSIONS (UNIT:MM)

5.0X 3.2 X 0.75 MM

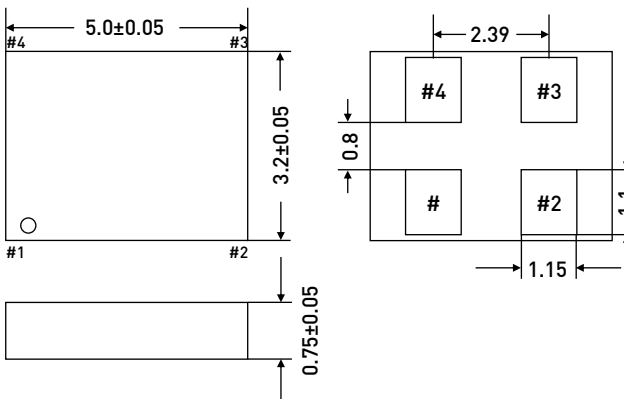

RECOMMENDED LAND PATTERN (UNIT:MM) ^[3]

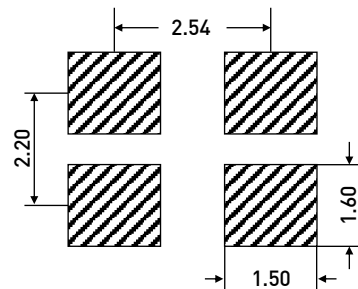

Note:
3. A capacitor value of 0.1 µF between VDD and GND is recommended.

DIMENSIONS AND PATTERNS

PACKAGE SIZE – DIMENSIONS (UNIT:MM)

7.0X 5.0 X 0.90 MM

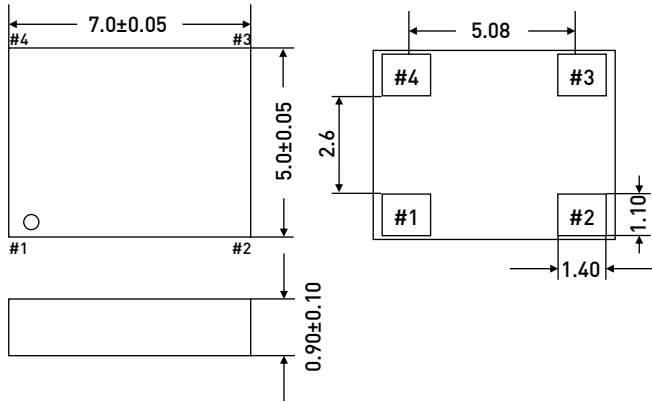

RECOMMENDED LAND PATTERN (UNIT:MM)^[3]

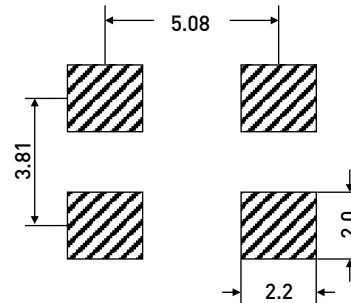

REFLOW SOLDER PROFILE

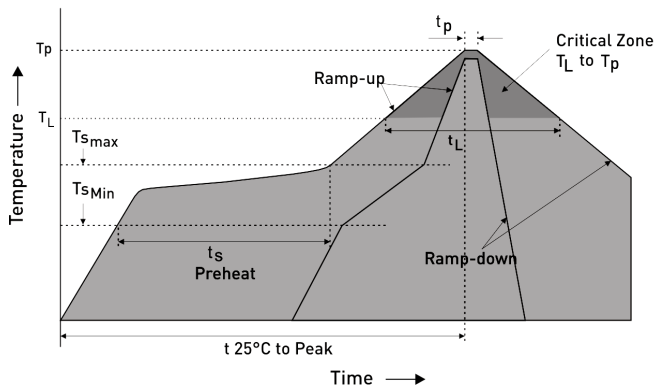

IPC/JEDEC Standard	IPC/JEDEC J-STD-020
Moisture Sensitivity Level	Level 1
TS MAX to TL (Ramp-up Rate)	3°C/second Maximum
Preheat	
- Temperature Minimum (TS MIN)	150°C
- Temperature Typical (TS TYP)	175°C
- Temperature Typical (TS MAX)	200°C
- Time (tS)	60 - 180 Seconds
Ramp-up Rate (TL to TP)	3°C/second Maximum
Time Maintained Above:	
- Temperature (TL)	217°C
- Time (TL)	60 - 150 Seconds
Peak Temperature (TP)	260°C Maximum
Target Peak Temperature (TP Target)	255°C
Time within 5°C of actual peak (tP)	20 - 40 Seconds
Max. Number of Reflow Cycles	3
Ramp-down Rate	6°C/second Maximum
Time 25°C to Peak Temperature (t)	8 minutes Maximum

Note:

3. A capacitor value of 0.1 μ F between VDD and GND is recommended.

ORDERING INFORMATION

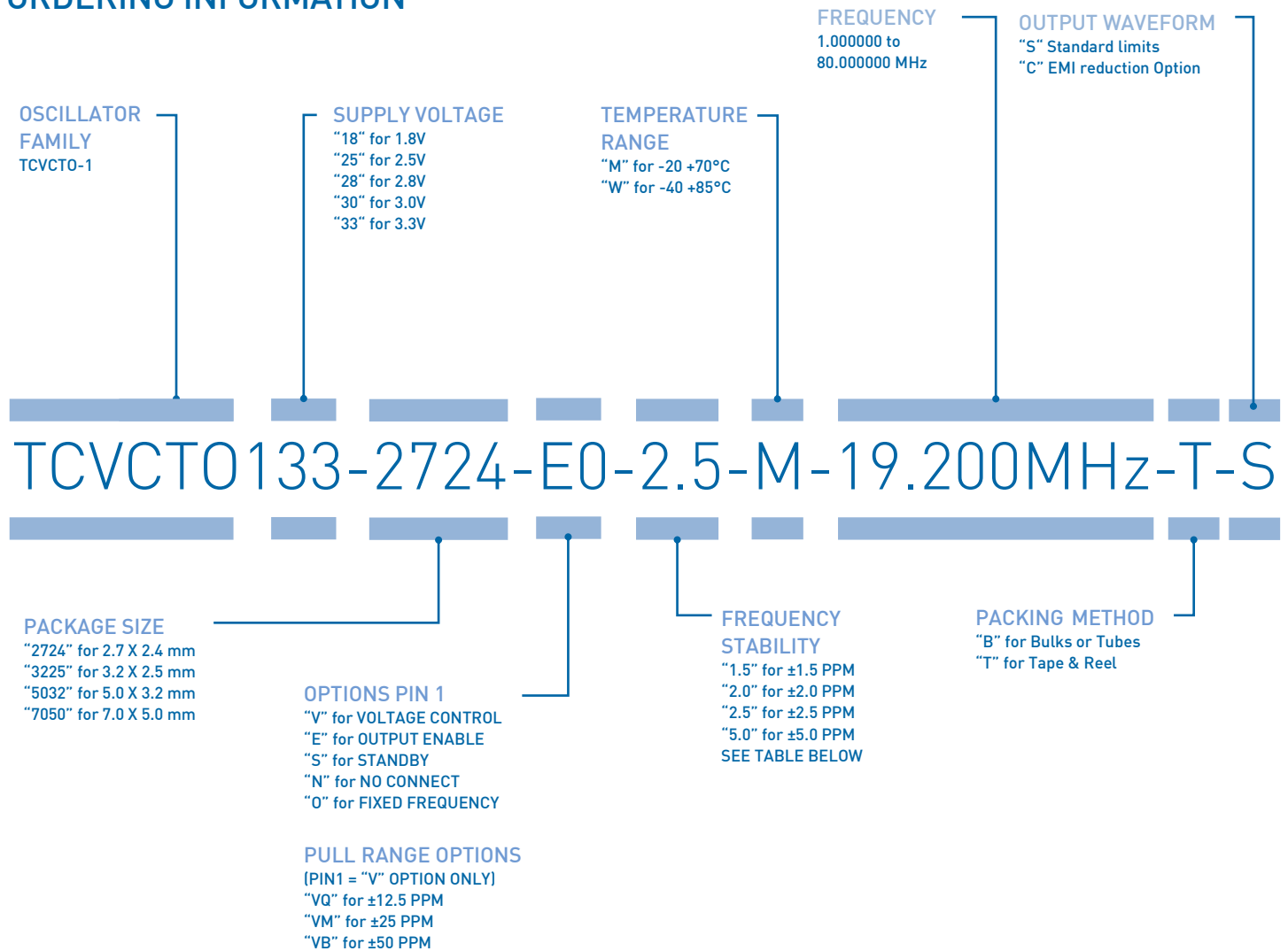

EXAMPLE: TCVCT0133-2724-E0-2.5-M-19.200MHz-T-S
[PLEASE CLICK HERE TO CREATE YOUR OWN ORDERING CODE](#)

SAMPLES ARE AVAILABLE WITHIN A SHORT DELIVERY PERIOD!



Frequency Stability (PPM) Temperature Range

FREQUENCY STABILITY (PPM)	TEMPERATURE RANGE	
	M (-20 to +70°C)	W (-40 to +85°C)
±5	✓	✓
±2.5	✓	✓
±2	✓	✓
±1.5	✓	Contact PETERMANN-TECHNIK
±1	Contact PETERMANN-TECHNIK	Contact PETERMANN-TECHNIK
±0.5	Contact PETERMANN-TECHNIK	Contact PETERMANN-TECHNIK



PREMIUM QUALITY BY PETERMANN-TECHNIK



OUR COMPANY IS CERTIFIED ACCORDING TO ISO 9001:2015 IN OCTOBER 2016 BY THE DMSZ CERTIFIKATION GMBH.

THIS IS FOR YOU TO ENSURE THAT THE PRINCIPLES OF QUALITY MANAGEMENT ARE FULLY IMPLEMENTED IN OUR QUALITY MANAGEMENT SYSTEM AND QUALITY CONTROL METHODS ALSO DOMINATE OUR QUALITY STANDARDS.