

ULTRA PERFORMANCE OSCILLATOR 1.0—80.0 MHz

SERIES „UPO“

FEATURES

- + Ultra Performance Oscillator for Low Cost
- + Low Power Consumption / Ultra low phase Jitter
- + Excellent long time reliability
- + Very tight frequency stability as low as ± 10 ppm
- + Outstanding long term aging of ± 5 ppm after 10 years
- + LVCMOS/LVTTL compatible output
- + Standard housings: 2.5x2.0; 3.2x2.5; 5.0x3.2; 7.0x5.0mm
- + Express samples within 1 day ex works PETERMANN-TECHNIK
- + Pb-free, RoHS and REACH compliant / MSL1@260°C

APPLICATIONS

- + SATA, SAS, Ethernet, PCI Express, video, WiFi
- + Computing, storage, networking, telecom, industrial control,
- + etc.

GENERAL DATA^[1]

PARAMETER AND CONDITIONS	SYMBOL	MIN.	TYP.	MAX.	UNIT	CONDITION
FREQUENCY RANGE						
Output Frequency Range	f	1	–	80	MHz	
FREQUENCY STABILITY AND AGING						
Frequency Stability	F_stab	-10		+10	PPM	Inclusive of initial tolerance at 25°C, and variations over operating temperature, rated power supply voltage and load
		-20	–	+20	PPM	
		-25	–	+25	PPM	
		-50	–	+50	PPM	
First year Aging	F_aging	-1.5	–	+1.5	PPM	25°C
10-year Aging		-5	–	+5	PPM	25°C
OPERATING TEMPERATURE RANGE						
Operating Temperature Range	T_use	-20	–	+70	°C	Extended Commercial
		-40	–	+85	°C	Industrial
Storage Temperature Range	T_stor	-55	–	+125	°C	Storage
SUPPLY VOLTAGE AND CURRENT CONSUMPTION						
Supply Voltage	V _{DD}	1.71	1.8	1.89	V	Supply voltages between 2.5V and 3.3V can be supported. Contact PETERMANN-TECHNIK for additional information.
		2.25	2.5	2.75	V	
		2.52	2.8	3.08	V	
		2.97	3.3	3.63	V	
Current Consumption	I _{DD}	–	31	33	mA	No load condition, f = 20 MHz, V _{DD} = 2.5V, 2.8V or 3.3V
		–	29	31	mA	No load condition, f = 20 MHz, V _{DD} = 1.8V
OE Disable Current	I _{OD}	–	–	31	mA	V _{DD} = 2.5V, 2.8V or 3.3V, OE = GND, output is pulled down
		–	–	30	mA	V _{DD} = 1.8 V. OE = GND, output is pulled down
Standby Current	I _{std}	–	–	70	µA	V _{DD} = 2.5V, 2.8V or 3.3V, ST = GND, output is pulled down
		–	–	10	µA	V _{DD} = 1.8 V. ST = GND, output is pulled down

Note:

1. All electrical specifications in the above table are specified with 15 pF output load at default drive strength and for all V_{DD}(s) unless otherwise stated.

GENERAL DATA^[1] (continued)

PARAMETER AND CONDITIONS	SYMBOL	MIN.	TYP.	MAX.	UNIT	CONDITION
LVCNMOS OUTPUT CHARACTERISTICS						
Duty Cycle	DC	45	–	55	%	
Rise/Fall Time	Tr, Tf	–	1.2	2	ns	15 pF load, 10% - 90% VDD
Output Voltage High	VOH	90%	–	–	VDD	IOH = -6 mA, IOL = 6 mA, (VDD = 3.3V, 2.8V, 2.5V)
Output Voltage Low	VOL	–	–	10%	VDD	IOL = 3 mA, (VDD = 1.8V)
INPUT CHARACTERISTICS						
Input Voltage High	VIH	70%	–	–	VDD	Pin 1, OE or ST
Input Voltage Low	VIL	–	–	30%	VDD	Pin 1, OE or ST
Input Pull-up Impedance	Z_in	–	100	250	kΩ	Pin 1, OE logic high or logic low, or ST logic high
		2	–	–	MΩ	Pin 1, ST logic low
STARTUP AND RESUME TIMING						
Startup Time	T_start	–	7	10	ms	Measured from the time VDD reaches its rated minimum value
OE Enable/Disable Time	T_oe	–	–	150	ns	f = 80 MHz, For other frequencies, T_oe = 100 ns + 3 cycles
Resume Time	T_resume	–	6	10	ms	In standby mode, measured from the time ST pin crosses 50% threshold. Refer to Figure 5.
JITTER						
RMS Period Jitter	T_jitt	–	1.5	2	ps	
		–	2	3	ps	f = 75 MHz, VDD = 1.8V
RMS Phase Jitter (random)	T_phj	–	0.5	1	ps	f = 10 MHz, Integration bandwidth = 12 kHz to 20 MHz
EXCELLENT RELIABILITY DATA						
MTBF						500 million hours
Shock Resistance:						10.000 g
Vibration Resistance:						70 g

Note:

- All electrical specifications in the above table are specified with 15 pF output load and for all VDD(s) unless otherwise stated.

PIN DESCRIPTION

PIN	SYMBOL	FUNCTIONALITY
1	OE/ST	Output Enable H or Open ^[2] : specified frequency output L: output is high impedance. Only output driver is disabled.
		Standby H or Open ^[2] : specified frequency output L: output is low (weak pull down). Device goes to sleep mode. Supply current reduces to I_std.
2	GND	Electrical ground ^[3]
3	OUT	Output Oscillator output
4	VDD	Power Power supply voltage ^[3]

TOP VIEW

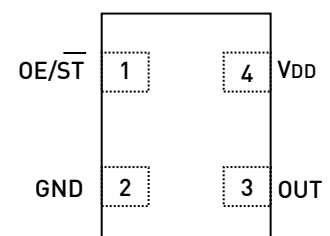

Notes:

- A pull-up resistor of <10 kΩ between OE/ST pin and VDD is recommended in high noise environment.
- A capacitor value of 0.1 μF between VDD and GND is recommended.

TEST CIRCUIT AND WAVEFORM

FIGURE 1. TEST CIRCUIT

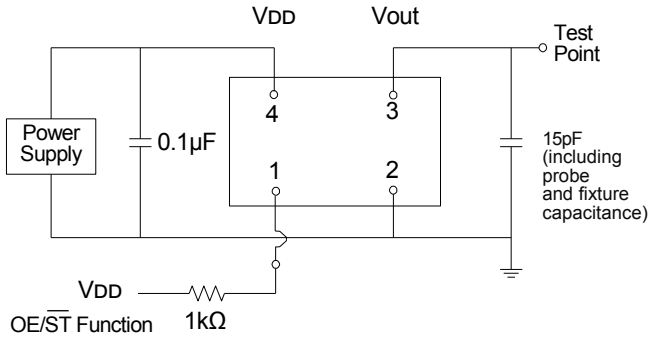
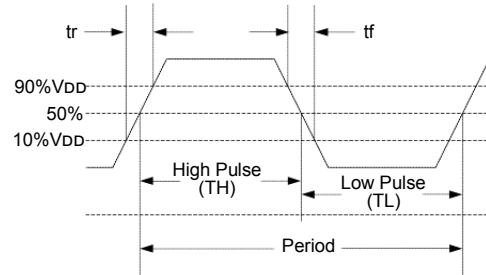

FIGURE 2. WAVEFORM



TIMING DIAGRAMS

FIGURE 3. STARTUP TIMING (OE/ST MODE)

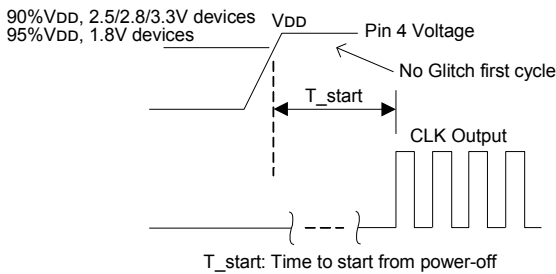

FIGURE 4. STANDBY RESUME TIMING (ST MODE ONLY)

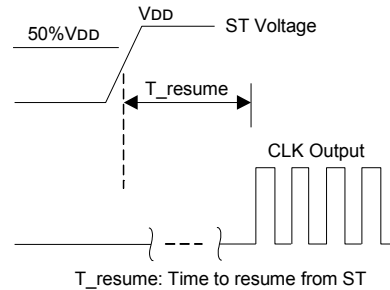

FIGURE 5. OE ENABLE TIMING (OE MODE ONLY)

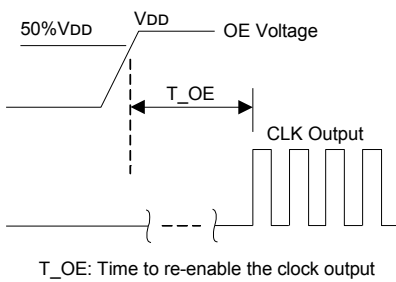
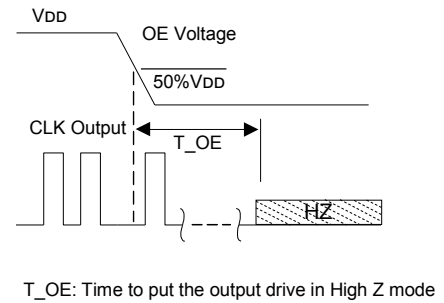

FIGURE 6. OE DISABLE TIMING (OE MODE ONLY)



Notes:

4. Duty Cycle is computed as Duty Cycle = TH/Period.
5. UPO supports the configurable duty cycle feature. For custom duty cycle at any given frequency, contact PETERMANN-TECHNIK.
6. UPO supports NO RUNT pulses and No glitches during startup or resume.
7. UPO supports gated output which is accurate within rated frequency stability from the first cycle.

PROGRAMMABLE DRIVE STRENGTH

The UPO includes a programmable drive strength feature named SoftLevel to provide a simple, flexible tool to optimize the clock rise/fall time for specific applications. Benefits from the programmable drive strength feature are:

- + Improves system radiated electromagnetic interference (EMI) by slowing down the clock rise/fall time
- + Improves the downstream clock receiver's (RX) jitter by decreasing (speeding up) the clock rise/fall time.
- + Ability to drive large capacitive loads while maintaining full swing with sharp edge rates.

For more detailed information about rise/fall time control and drive strength selection, see the PETERMANN-TECHNIK Applications Note section: <http://www.petermann-technik.com>

EMI REDUCTION BY SLOWING RISE/FALL TIME (SoftLevel FUNCTION)

Figure 13 shows the harmonic power reduction as the rise/fall times are increased (slowed down). The rise/fall times are expressed as a ratio of the clock period. For the ratio of 0.05, the signal is very close to a square wave. For the ratio of 0.45, the rise/fall times are very close to near-triangular waveform. These results, for example, show that the 11th clock harmonic can be reduced by 35 dB if the rise/fall edge is increased from 5% of the period to 45% of the period.

FIGURE 7. HARMONIC EMI REDUCTION AS A FUNCTION OF SLOWER RISE/FALL TIME (SoftLevel FUNCTION)

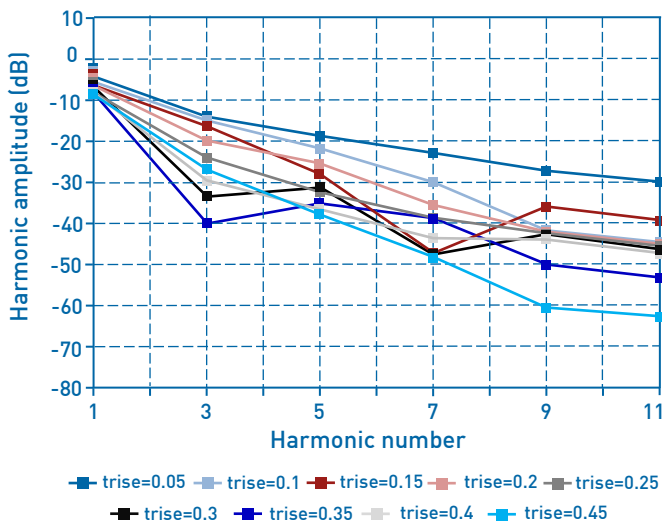

JITTER REDUCTION WITH FASTER RISE/FALL TIME

Power supply noise can be a source of jitter for the downstream chipset. One way to reduce this jitter is to increase rise/fall time (edge rate) of the input clock. Some chipsets would require faster rise/fall time in order to reduce their sensitivity to this type of jitter. The UPO provides up to 3 additional high drive strength settings for very fast rise/fall time. Refer to the Rise/Fall Time Tables to determine the proper drive strength.

HIGH OUTPUT LOAD CAPABILITY

The rise/fall time of the input clock varies as a function of the actual capacitive load the clock drives. At any given drive strength, the rise/fall time becomes slower as the output load increases. As an example, for a 3.3V UPO device with default drive strength setting, the typical rise/fall time is 1.15ns for 15 pF output load. The typical rise/fall time slows down to 2.72ns when the output load increases to 45 pF. One can choose to speed up the rise/fall time to 1.41ns by then increasing the drive strength setting on the UPO.

The UPO can support up to 60 pF or higher in maximum capacitive loads with up to 3 additional drive strength settings. Refer to the Rise/Fall Time Tables to determine the proper drive strength for the desired combination of output load vs. rise/fall time.

UPO DRIVE STRENGTH SELECTION

Tables 1 through 4 define the rise/fall time for a given capacitive load and supply voltage.

1. Select the table that matches the UPO nominal supply voltage (1.8V, 2.5V, 2.8V, 3.0V, 3.3V).
2. Select the capacitive load column that matches the application requirement (5 pF to 60 pF)
3. Under the capacitive load column, select the desired rise/fall times.
4. The left-most column represents the part number code for the corresponding drive strength.
5. Add the drive strength code to the part number for ordering purposes.

CALCULATING MAXIMUM FREQUENCY

Based on the rise and fall time data given in Tables 1 through 4, the maximum frequency the oscillator can operate with guaranteed full swing of the output voltage over temperature as follows:

$$\text{Max. Frequency} = \frac{1}{6 \times (\text{Trise})}$$

EXAMPLE 1

Calculate f_{MAX} for the following condition:

- + $V_{\text{DD}} = 1.8\text{V}$ (Table 1)
- + Capacitive Load: 30pF
- + Desired Tr/f time = 3ns (rise/fall time part number code=G)

Part number for the above example:

UPO18-2724-E-10-M-25.000MHZ-T-S

Drive strength code is inserted here. S = standard value.

RISE/FALL TIME (10% TO 90%) vs C_{LOAD}

TABLE 1. V_{DD} = 1.8V RISE/FALL TIMES FOR SPECIFIC C_{LOAD}

RISE/FALL TIME TYP (NS)					
Drive Strength \ C _{LOAD}	5 pF	15 pF	30 pF	45 pF	60 pF
L	12.45	17.68	19.48	46.21	57.82
A	6.50	10.27	16.21	23.92	30.73
R	4.38	7.05	11.61	16.17	20.83
B	3.27	5.30	8.89	12.18	15.75
S	2.62	4.25	7.20	9.81	12.65
D	2.19	3.52	6.00	8.31	10.59
T	1.76	3.01	5.14	7.10	9.15
E	1.59	2.59	4.49	6.25	7.98
U	1.49	2.28	3.96	5.55	7.15
F	1.22	2.10	3.57	5.00	6.46
W	1.07	1.88	3.23	4.50	5.87
G	1.01	1.64	2.95	4.12	5.40
X	0.96	1.50	2.74	3.80	4.98
K	0.92	1.41	2.56	3.52	4.64
Y	0.88	1.34	2.39	3.25	4.32
Q	0.86	1.29	2.24	3.04	4.06
S for standard value	0.82	1.24	2.07	2.89	3.82
M	0.77	1.20	1.94	2.72	3.61
N	0.66	1.15	1.84	2.58	3.41
P	0.51	1.09	1.76	2.45	3.24

TABLE 2. V_{DD} = 2.5V RISE/FALL TIMES FOR SPECIFIC C_{LOAD}

RISE/FALL TIME TYP (NS)					
Drive Strength \ C _{LOAD}	5 pF	15 pF	30 pF	45 pF	60 pF
L	8.68	13.59	18.36	32.70	42.06
A	4.42	7.18	11.93	16.60	21.38
R	2.93	4.78	8.15	11.19	14.59
B	2.21	3.57	6.19	8.55	11.04
S	1.67	2.87	4.94	6.85	8.80
D	1.50	2.33	4.11	5.68	7.33
T	1.06	2.04	3.50	4.84	6.26
E	0.98	1.69	3.03	4.20	5.51
U	0.93	1.48	2.69	3.73	4.92
F	0.90	1.37	2.44	3.34	4.42
W	0.87	1.29	2.21	3.04	4.02
S for standard value	0.67	1.20	2.00	2.79	3.69
X	0.44	1.10	1.86	2.56	3.43
K	0.38	0.99	1.76	2.37	3.18
Y	0.36	0.83	1.66	2.20	2.98
Q	0.34	0.71	1.58	2.07	2.80
Z	0.33	0.65	1.51	1.95	2.65
M	0.32	0.62	1.44	1.85	2.50
N	0.31	0.59	1.37	1.77	2.39
P	0.30	0.57	1.29	1.70	2.28

TABLE 3. V_{DD} = 2.8V RISE/FALL TIMES FOR SPECIFIC C_{LOAD}

RISE/FALL TIME TYP (NS)					
Drive Strength \ C _{LOAD}	5 pF	15 pF	30 pF	45 pF	60 pF
L	7.93	12.69	17.94	30.10	38.89
A	4.06	6.66	11.04	15.31	19.80
R	2.68	4.40	7.53	10.29	13.37
B	2.00	3.25	5.66	7.84	10.11
S	1.59	2.57	4.54	6.27	8.07
D	1.19	2.14	3.76	5.21	6.72
T	1.00	1.79	3.20	4.43	5.77
E	0.94	1.51	2.78	3.84	5.06
U	0.90	1.38	2.48	3.40	4.50
F	0.87	1.29	2.21	3.03	4.05
W	0.62	1.19	1.99	2.76	3.68
S for standard value	0.41	1.08	1.84	2.52	3.36
X	0.37	0.96	1.72	2.33	3.15
K	0.35	0.78	1.63	2.15	2.92
Y	0.33	0.67	1.54	2.00	2.75
Q	0.32	0.63	1.46	1.89	2.57
Z	0.31	0.60	1.39	1.80	2.43
M	0.30	0.57	1.31	1.72	2.30
N	0.30	0.56	1.22	1.63	2.22
P	0.29	0.54	1.13	1.55	2.13

TABLE 4. V_{DD} = 3.3V RISE/FALL TIMES FOR SPECIFIC C_{LOAD}

RISE/FALL TIME TYP (NS)					
Drive Strength \ C _{LOAD}	5 pF	15 pF	30 pF	45 pF	60 pF
L	7.18	11.59	17.24	27.57	35.57
A	3.61	6.02	10.19	13.98	18.10
R	2.31	3.95	6.88	9.42	12.24
B	1.65	2.92	5.12	7.10	9.17
S	1.43	2.26	4.09	5.66	7.34
D	1.01	1.91	3.38	4.69	6.14
T	0.94	1.51	2.86	3.97	5.25
E	0.90	1.36	2.50	3.46	4.58
U	0.86	1.25	2.21	3.03	4.07
S for standard value	0.48	1.15	1.95	2.72	3.65
W	0.38	1.04	1.77	2.47	3.31
G	0.36	0.87	1.66	2.23	3.03
X	0.34	0.70	1.56	2.04	2.80
K	0.33	0.63	1.48	1.89	2.61
Y	0.32	0.60	1.40	1.79	2.43
Q	0.32	0.58	1.31	1.69	2.28
Z	0.30	0.56	1.22	1.62	2.17
M	0.30	0.55	1.12	1.54	2.07
N	0.30	0.54	1.02	1.47	1.97
P	0.29	0.52	0.95	1.41	1.90

DIMENSIONS AND PATTERNS

PACKAGE SIZE – DIMENSIONS (UNIT:MM)

2.7X 2.4 X 0.75 MM [100% COMPATIBLE WITH 2.5X2.0MM FOOTPRINT]

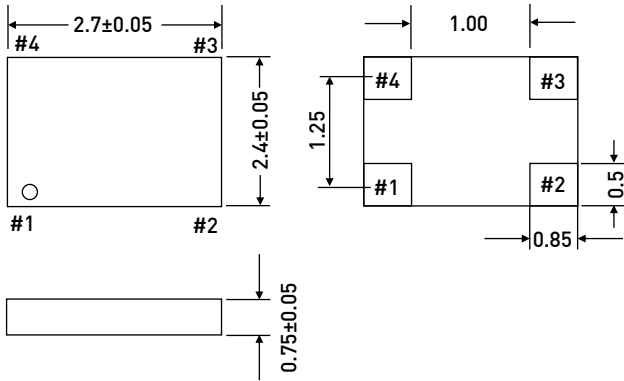

RECOMMENDED LAND PATTERN (UNIT:MM) [8]

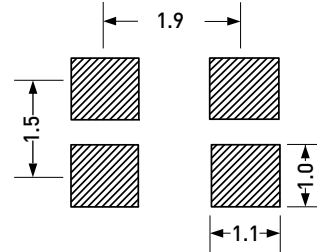

PACKAGE SIZE – DIMENSIONS (UNIT:MM)

3.2 X 2.5 X 0.75 MM

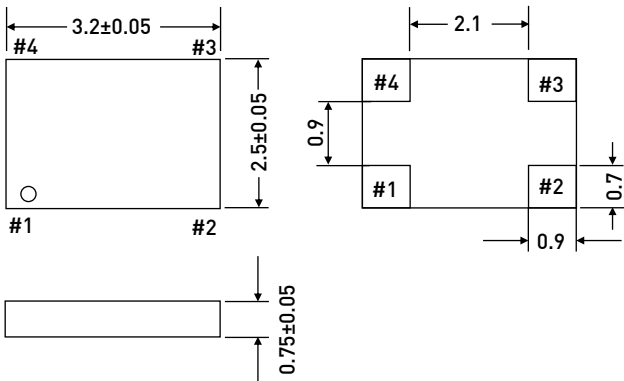

RECOMMENDED LAND PATTERN (UNIT:MM) [8]

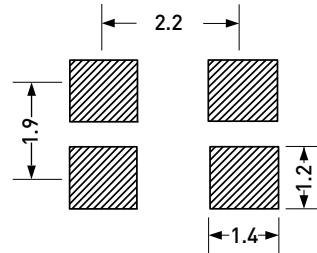

PACKAGE SIZE – DIMENSIONS (UNIT:MM)

5.0 X 3.2 X 0.75 MM

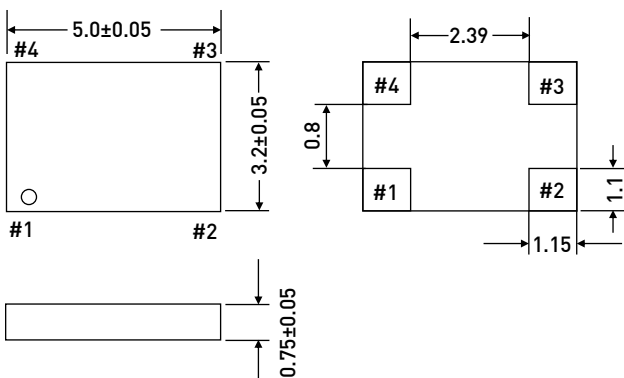

RECOMMENDED LAND PATTERN (UNIT:MM) [8]

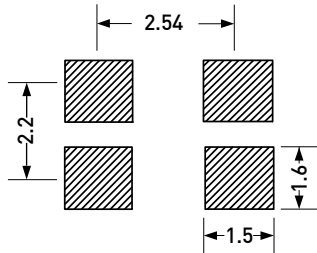

Note:
 8. A capacitor value of 0.1 µF between VDD and GND is recommended.

DIMENSIONS AND PATTERNS

PACKAGE SIZE – DIMENSIONS (UNIT:MM)

7.0 X 5.0 X 0.90 MM

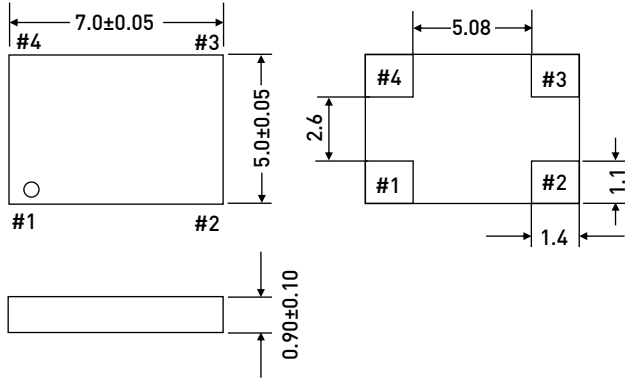

RECOMMENDED LAND PATTERN (UNIT:MM)^[8]

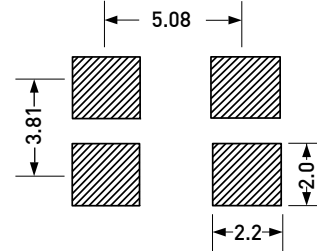

REFLOW SOLDER PROFILE

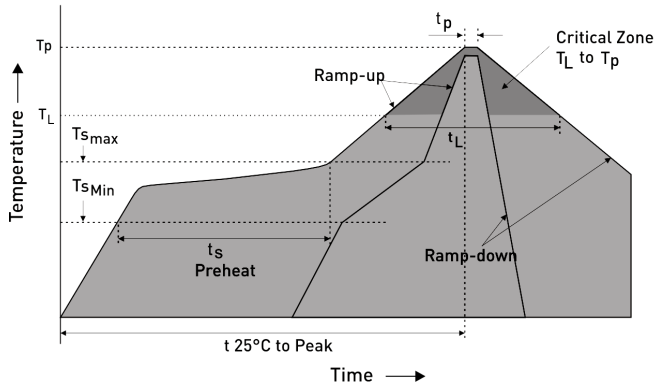

IPC/JEDEC Standard	IPC/JEDEC J-STD-020
Moisture Sensitivity Level	Level 1
TS MAX to TL (Ramp-up Rate)	3°C/second Maximum
Preheat	
- Temperature Minimum (TS MIN)	150°C
- Temperature Typical (TS TYP)	175°C
- Temperature Typical (TS MAX)	200°C
- Time (tS)	60 - 180 Seconds
Ramp-up Rate (TL to TP)	3°C/second Maximum
Time Maintained Above:	
- Temperature (TL)	217°C
- Time (TL)	60 - 150 Seconds
Peak Temperature (TP)	260°C Maximum
Target Peak Temperature (TP Target)	255°C
Time within 5°C of actual peak (tP)	20 - 40 Seconds
Max. Number of Reflow Cycles	3
Ramp-down Rate	6°C/second Maximum
Time 25°C to Peak Temperature (t)	8 minutes Maximum

Note:

8. A capacitor value of 0.1 μ F between VDD and GND is recommended.

ORDERING INFORMATION

OSCILLATOR
FAMILY
UPO

SUPPLY VOLTAGE

"18" for 1.8V
"25" for 2.5V
"28" for 2.8V
"33" for 3.3V

TEMPERATURE
RANGE

"M" for -20 +70°C
"W" for -40 +85°C

FREQUENCY

1.000000 to
80.000000 MHz

UPO 33-2724-E-10-M-25.000MHz-T-S

FREQUENCY
STABILITY

"10" for ±10 PPM
"20" for ±20 PPM
"25" for ±25 PPM
"50" for ±50 PPM

PACKING METHOD
"B" for BULKs or TUBES
"T" for TAPE & REEL

PACKAGE SIZE

"2724" for 2.7 X 2.4 mm
"3225" for 3.2 X 2.5 mm
"5032" for 5.0 X 3.2 mm
"7050" for 7.0 X 5.0 mm

FEATURE PIN 1

"E" for OUTPUT ENABLE
"S" for STANDBY

OUTPUT DRIVE
STRENGTH

"S" Standard (datasheet
limits) See Tables 1 to 4
for rise/fall times
"L" "D" "W" "Q"
"A" "T" "G" "Z"
"R" "E" "X" "M"
"B" "U" "K" "N"
"S" "F" "Y" "P"

EXAMPLE: UPO33-2724-E-10-M-25.000MHz-T-S

[PLEASE CLICK HERE TO CREATE YOUR OWN
ORDERING CODE](#)

**EXPRESS SAMPLES ARE DELIVERABLE ON THE SAME DAY
IF ORDERED UNTIL 02:00 PM!**



PREMIUM QUALITY BY PETERMANN-TECHNIK



OUR COMPANY IS CERTIFIED ACCORDING TO ISO 9001:2015 IN OCTOBER 2016 BY THE DMSZ CERTIFIKATION GMBH.

THIS IS FOR YOU TO ENSURE THAT THE PRINCIPLES OF QUALITY MANAGEMENT ARE FULLY IMPLEMENTED IN OUR QUALITY MANAGEMENT SYSTEM AND QUALITY CONTROL METHODS ALSO DOMINATE OUR QUALITY STANDARDS.